

EXCURSIONS IN
NON -EUCLIDIAN
GEOMETRY

By
Saul Stahl

Copyright 2019

MASS IN HYPERBOLIC GEOMETRY*

Saul Stahl

March 13, 2008

Department of Mathematics
University of Kansas
Lawrence, KS 66045, USA

1 INTRODUCTION

Archimedes computed the center of mass of several regions and solid bodies [Dijksterhuis], and this fundamental physical notion may very well be due to him. He based his investigations of this concept on the notion of moment as it is used in his Law of the Lever. A hyperbolic version of this law was formulated in the nineteenth century leading to the notion of a hyperbolic center of mass of two point-masses [Andrade, Bonola]. In 1969 Perron extended the notions of mass and center of mass to arbitrary regions of hyperbolic space. In 1987 Gal'perin proposed an axiomatic definition of the center of mass of finite systems of point-masses in Euclidean, hyperbolic and elliptic n -dimensional spaces and proved its uniqueness. Ungar [2004] used the theory of gyrogroups to show that in hyperbolic geometry the center of mass of three point-masses of equal mass coincides with the point of intersection of the medians, a fact that had already been noted by Perron. Some information regarding the centroids of finite point sets in spherical spaces can be found in [Fog, Fabricius-Bjerre].

In this article we begin by offering yet another physical motivation for the hyperbolic Law of the Lever and summarize Perron's treatment of the subjects of mass and centers of mass (centroids). The masses and centroids of several geometric objects are derived. Surprisingly, the hyperbolic mass formulas are quite similar to the Euclidean ones whereas, as is well known, the formulas for hyperbolic area and volume look nothing like their Euclidean analogs.

For general information regarding the hyperbolic plane the reader is referred to [Greenberg, Ratcliffe, Stahl2].

*This research was supported in part by University of Kansas General Research Allocation 2301559-003

This article has the following structure:

- Section 1: Introduction
- Section 2: The Hyperbolic Law of the Lever
- Section 3: A Summary of Perron's Results
- Section 4: Planar Examples
- Section 5: Higher Dimensions
- Section 6: Formulas of the Hyperbolic Triangle

2 THE HYPERBOLIC LAW OF THE LEVER

Many hyperbolic formulas can be obtained from their Euclidean analogs by the mere replacement of a length d by $\sinh d$. The Law of Sines and the Theorems of Menelaus and Ceva (see Appendix) are cases in point. It therefore would make sense that for a lever in the hyperbolic plane a suitable definition of the *moment* of a force w acting perpendicularly at distance d from the fulcrum is

$$w \sinh d.$$

Nevertheless, a more physical motivation is in order. We begin with an examination of the balanced weightless lever of Figure 1. This lever is pivoted at E and has masses of weights w_1 and w_2 at A and B respectively. By this is meant that there is a mass D , off the lever, which exerts attractive forces \vec{w}_1 and \vec{w}_2 along the straight lines AD and BD . Since this system is assumed to be in equilibrium, it follows that the resultant of the forces \vec{w}_1 and \vec{w}_2 acts along the straight line ED . Neither the direction nor the intensity of the resultant are affected by the addition of a pair of equal but opposite forces \vec{f}_1 and \vec{f}_2 at A and B . (Here and below we employ the convention that the magnitude of the vector \vec{v} is denoted by v .) We assume that the common magnitude of f_1 and f_2 is large enough so that the lines of direction of the partial resultants $\vec{r}_i = \vec{f}_i + \vec{w}_i, i = 1, 2$, intersect in some point, say C . Note that the quadrilateral $ACBD$ lies in the hyperbolic plane whereas the parallelograms of forces at A and B lie in the respective Euclidean tangent planes. This is a standard operating procedure in mathematical physics.

It is now demonstrated that such a system in equilibrium must satisfy the equation

$$F_1 \sinh c_1 = F_2 \sinh c_2 \tag{1}$$

where each F_i is the component of \vec{w}_i in the direction orthogonal to AB . Indeed, it follows from several applications of both the Euclidean and the hyperbolic Laws of Sines that

$$\frac{w_1 \sinh c_1}{w_2 \sinh c_2} = \frac{w_1 \sin \gamma_1 \cdot \frac{\sinh a}{\sin \delta_1}}{w_2 \sin \gamma_2 \cdot \frac{\sinh b}{\sin \delta_2}} = \frac{w_1 \sin \gamma_1 \sinh a}{w_2 \sin \gamma_2 \sinh b} =$$

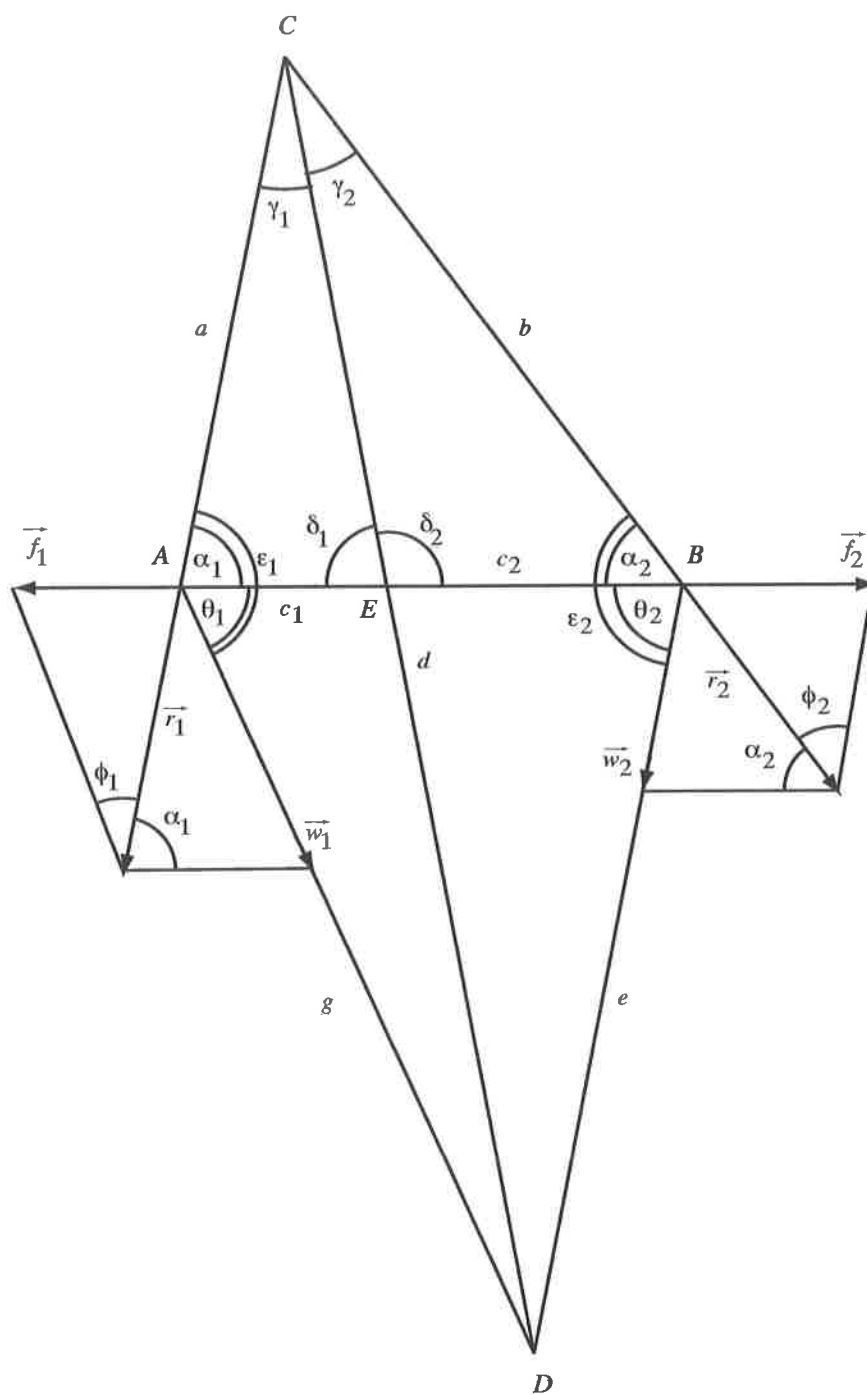

Figure 1:

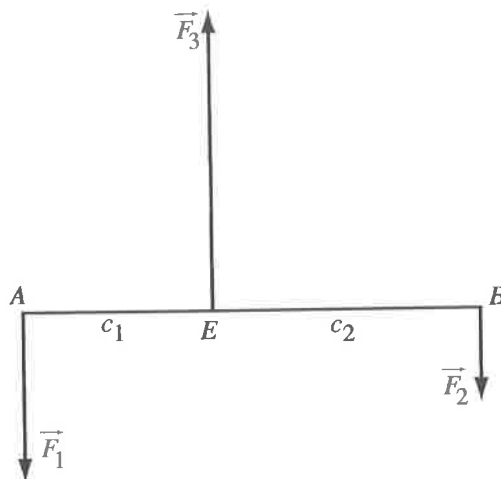

Figure 2:

$$\frac{\sin \gamma_1 \cdot \frac{w_1}{\sin \alpha_1}}{\sin \gamma_2 \cdot \frac{w_2}{\sin \alpha_2}} = \frac{\sin \gamma_1 \cdot \frac{f_1}{\sin \phi_1}}{\sin \gamma_1 \cdot \frac{f_2}{\sin \phi_2}} = \frac{\sin \gamma_1}{\sin \gamma_2} \frac{\sin \epsilon_2}{\sin \epsilon_1} =$$

$$\frac{\frac{\sin \epsilon_2}{\sin \gamma_2}}{\frac{\sin \epsilon_1}{\sin \gamma_1}} = \frac{\frac{\sinh d}{\sinh e}}{\frac{\sinh d}{\sinh g}} = \frac{\sinh g}{\sinh e} = \frac{\sin \theta_2}{\sin \theta_1}$$

and Eq'n (1) follows by cross-multiplication.

If we take the mass at D out of the picture and stipulate that \vec{F}_1 and \vec{F}_2 are simply two forces that act perpendicularly to the lever AB (Fig. 2) then it makes sense to regard the quantities

$$F_1 \sinh c_1 \quad \text{and} \quad F_2 \sinh c_2$$

as the respective moments of the forces \vec{F}_1 and \vec{F}_2 with respect to the pivot point E . This facilitates the derivation of the resultant of \vec{F}_1 and \vec{F}_2 . Suppose $\vec{F}_3 \perp AB$ at E , and c_1, c_2 are such that

$$F_1 \sinh c_1 = F_2 \sinh c_2 \quad \text{and} \quad F_3 = F_1 \cosh c_1 + F_2 \cosh c_2 \quad (2)$$

Then the moments of \vec{F}_3 with respect to A and B are, respectively

$$(F_1 \cosh c_1 + F_2 \cosh c_2) \sinh c_1$$

$$= F_2 \cosh c_1 \sinh c_2 + F_2 \sinh c_1 \cosh c_2 = F_2 \sinh(c_1 + c_2)$$

and

$$(F_1 \cosh c_1 + F_2 \cosh c_2) \sinh c_2 = F_1 \sinh(c_1 + c_2).$$

Since the right hand sides of these two equations, are, respectively, the moments of \vec{F}_2 with respect to A and the moment of \vec{F}_1 with respect to B , it follows that the equations of (2) do indeed imply equilibrium. Consequently, the reverse of \vec{F}_3 is indeed the resultant of \vec{F}_1 and \vec{F}_2 .

3 A SUMMARY OF PERRON'S RESULTS

The physical considerations of the previous section motivate the following formal definitions. A *point-mass* is an ordered pair (X, x) where its *location* X is a point of hyperbolic space H^n and its *weight* x is a nonnegative real number. The (*unsigned*) *moment* of the point-mass (X, x) with respect to the hyperplane Π is, respectively,

$$M_{\Pi}(X, x) = x \sinh d(X, \Pi)$$

where $d(X, \Pi)$ is the hyperbolic distance from X to Π .

Given any two point-masses (X, x) and (Y, y) , their *center of mass* or *centroid* $(X, x) * (Y, y)$ is the point-mass (Z, z) , where Z is that point between X and Y such that

$$x \sinh XZ = y \sinh YZ$$

and

$$z = x \cosh XZ + y \cosh YZ \quad (3)$$

Note that this means that the two point-masses have equal moments with respect to their centroid. Moreover, if $X = Y$ then $(X, x) * (Y, y) = (X, x+y)$.

The (*signed*) *moment* of the finite point-mass system $\mathcal{X} = \{(X_i, x_i), i = 1, 2, 3, \dots, n\}$ with respect to the oriented hyperplane Π is

$$M_{\Pi}(\mathcal{X}) = \sum_{i=1}^n \sigma_{\Pi}(X_i) M_{\Pi}(X_i, x_i)$$

where $\sigma_{\Pi}(X) = 1, -1, 0$ according as X is in the left half-space of m , right half-space of Π or on Π itself. The finite point-mass system \mathcal{X} is said to be *balanced* with respect to the oriented hyperplane Π provided

$$M_{\Pi}(\mathcal{X}) = 0.$$

It is clear that if Π and Π' are reverses of each other, then for every finite system \mathcal{X} we have

$$M_{\Pi}(\mathcal{X}) = -M_{\Pi'}(\mathcal{X})$$

and

$$M_{\Pi}(\mathcal{X}) = 0 \quad \text{if and only if} \quad M_{\Pi'}(\mathcal{X}) = 0$$

The following theorem was proved in [Perron] by means of the Weierstrass coordinates. A detailed synthetic proof can be found in [Stahl3]

Theorem 3.1 (Perron) *Given a finite point-mass system $\mathcal{X} = \{(X_i, x_i), i = 1, 2, 3, \dots, n\}$, there exists a unique point-mass*

$$\mathcal{C}(\mathcal{X}) = (C, c)$$

such that $C(\mathcal{X})$ and \mathcal{X} have the same signed moment with respect to every oriented hyperplane. Moreover,

$$c = \sum_{i=1}^n x_i \cosh[d(C, X_i)]$$

and

$$c^2 = \sum_{i,j=1}^n x_i x_j \cosh[d(X_i, X_j)].$$

□

A region in hyperbolic space H^n is a compact subset of H^n of finite positive measure. A (weighted) solid \mathcal{L} in H^n is a pair (L, λ) where L is an n -Lebesgue measurable region in H^n and λ is a continuous non-negative valued function on L such that

$$\int_L \lambda(X) dV > 0$$

where V is the volume element. The value $\lambda(X)$ is the density of \mathcal{L} at X . The solid is said to be uniform if its density is constant throughout L . When $n = 2$ it is customary to refer to weighted solids as laminae.

Let Π be an oriented hyperplane. We define the moment of \mathcal{L} with respect to Π as

$$M_{\Pi}(\mathcal{L}) = \int_L \sigma_{\Pi}(X) \lambda(X) \sinh[d(X, \Pi)] dV.$$

The hyperplane Π is said to balance the solid \mathcal{L} if $M_{\Pi}(\mathcal{L}) = 0$. The following theorem is surmised in [Perron] by analogy with Theorem 3.1. A detailed and intrinsic proof can be found in [Stahl3].

Theorem 3.2 (Perron) Given a weighted solid $\mathcal{L} = (L, \lambda)$ there exists a unique point

$$C(\mathcal{L}) = (C, c)$$

such that $C(\mathcal{L})$ and \mathcal{L} have the same signed moments with respect to every oriented hyperplane. Moreover,

$$c = \text{mass}(\mathcal{L}) = \int_L \lambda(X) \cosh[d(C, X)] dV$$

and

$$c^2 = \text{mass}(\mathcal{L})^2 = \int_L \int_L \lambda(X) \lambda(Y) \cosh[d(X, Y)] dV_X dV_Y.$$

□

In some cases the mass of a figure can be found by first evaluating the mass of its orbit under the action of a finite group (see Proposition 4.1, 4.2, and 4.3). This is facilitated by the following corollary and proposition.

Corollary 3.3 *Two solids have the same moment with respect to every oriented hyperplane if and only if they have identical centroids.*

□

A decomposition of \mathcal{L} is a family of sets $\tilde{L} = \{L_1, L_2, \dots, L_n\}$ such that

$$L = L_1 \cup L_2 \cup \dots \cup L_n$$

where distinct L_i 's intersect in sets of measure 0.

Proposition 3.4 *Let $\mathcal{L} = (L, \lambda)$ be a solid, $\tilde{L} = \{L_1, L_2, \dots, L_n\}$ a decomposition of \mathcal{L} and set*

$$\mathcal{L}_i = (L_i, \lambda|_{L_i}), \quad i = 1, 2, \dots, n.$$

Then

$$\mathcal{C}(\mathcal{L}) = \mathcal{C}(\mathcal{L}_1) * \mathcal{C}(\mathcal{L}_2) * \dots * \mathcal{C}(\mathcal{L}_n).$$

PROOF: It follows from Theorem 3.2 and the additivity of integrals that for any oriented hyperplane Π

$$\begin{aligned} M_{\Pi}[\mathcal{C}(\mathcal{L})] &= M_{\Pi}(\mathcal{L}) = M_{\Pi}(\mathcal{L}_1) + M_{\Pi}(\mathcal{L}_2) + \dots + M_{\Pi}(\mathcal{L}_n) \\ &= M_{\Pi}(\mathcal{C}(\mathcal{L}_1)) + M_{\Pi}(\mathcal{C}(\mathcal{L}_2)) + \dots + M_{\Pi}(\mathcal{C}(\mathcal{L}_n)) \\ &= M_{\Pi}[\mathcal{C}(\mathcal{L}_1) * \mathcal{C}(\mathcal{L}_2) * \dots * \mathcal{C}(\mathcal{L}_n)]. \end{aligned}$$

The validity of the proposition now follows from the arbitrariness of Π , Theorem 3.2 and Proposition 3.3. Q.E.D.

4 PLANAR EXAMPLES

Not surprisingly, we begin with a one dimensional figure.

Proposition 4.1 *The centroid of a hyperbolic line segment of length d and uniform density 1 is located at its midpoint and its mass is $2 \sinh(d/2)$.*

PROOF: The first part follows from a symmetry argument. The second part is valid because

$$2 \int_0^{d/2} \cosh x dx = 2 \sinh(d/2).$$

Q.E.D.

Some of the subsequent examples are worked out in a specific model of hyperbolic geometry that is based on a general geodesic polar parametrization used by Gauss in [Gauss]. This Gaussian model presents the hyperbolic

plane as a Riemannian geometry whose domain is the entire plane with polar coordinates (ρ, θ) and metric [Gauss, Ratcliffe, Stahl1]

$$d\rho^2 + \sinh^2 \rho d\theta^2$$

The geodesics of this metric are the Euclidean straight lines $\theta = c$ and the curves

$$\rho = \coth^{-1}(C \cos(\theta - \alpha))$$

where α is arbitrary and $C > 1$. Here $\coth^{-1}(C)$ is the distance from the origin to the geodesic and α is the angle of inclination of the line through the origin and perpendicular to the geodesic in question. The area element of this metric is

$$dA = \sinh \rho d\rho d\theta.$$

It is clear that mass is invariant under rigid motions and consequently the axes of reflections of a region contain its centroid. In particular the centroid of a uniform disk is located at its center.

Proposition 4.2 *The mass of a disk of uniform density 1 and hyperbolic radius r is*

$$\pi \sinh^2 r.$$

PROOF: We employ the Gauss model and assume that the disk is centered at the origin which coincides with its centroid. By the Theorem 3.2, the mass of this disk is

$$\int_0^{2\pi} \int_0^r \cosh \rho \sinh \rho d\rho d\theta = \pi \sinh^2 r.$$

Q.E.D.

This formula is particularly interesting for the following reason. As was noted above, many hyperbolic formulas can be obtained from their Euclidean analogs by the heuristic means of replacing a certain length d by $\sinh d$. One of the exceptions to this informal rule is the area of a circle of radius r . The Euclidean formula is

$$\pi r^2$$

whereas the hyperbolic formula is

$$4\pi \sinh^2 \left(\frac{r}{2} \right).$$

Thus, it would seem that while in Euclidean geometry area and uniform mass are essentially equivalent, in hyperbolic geometry, where they are distinct, sometimes it is the notion of mass that is better behaved (by Euclidean standards, of course). Other instances are offered in Propositions 4.4 and 4.5.

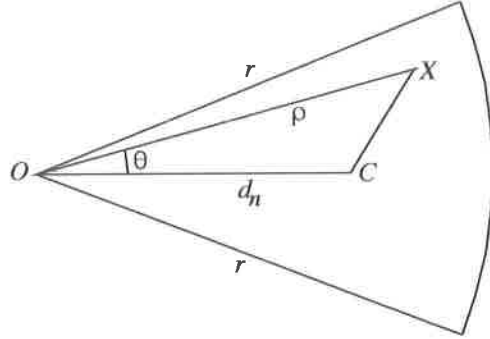

Figure 3:

We next turn to some uniform wedges. Let $D_n(r)$ denote the lamina consisting of the subset

$$\{(\rho, \theta) \in D_n(r) \mid -\frac{\pi}{n} \leq \theta \leq \frac{\pi}{n}\}$$

of the disk $D(r)$ with uniform density 1 (Fig. 3). Let $d_n(r)$ denote the distance from the origin O to $C(D_n(r))$ and let $R = R_{O, 2\pi/n}$ denote the counterclockwise rotation by the angle $2\pi/n$ about O .

Proposition 4.3 *For the uniform wedge $D_n(r)$*

$$\tanh d_n(r) = \frac{n}{\pi} \sin\left(\frac{\pi}{n}\right) \frac{\sinh 2r - 2r}{\cosh 2r - 1}$$

and

$$\text{mass}(D_n(r)) = \frac{\pi \sinh^2 r}{n \cosh d_n(r)}$$

PROOF: We abbreviate $D_n(r)$ and $d_n(r)$ to D_n and d_n , respectively. By symmetry, Proposition 3.4, and the Law of Cosines

$$\begin{aligned} \pi \sinh^2 r = \text{mass}(D(r)) &= \sum_{i=1}^n \text{mass}(R^i(D)) \cosh d_n = n \text{mass}(D_n) \cosh d_n \\ &= n \cosh d_n \int_{-\pi/n}^{\pi/n} \int_0^r \cosh[d(C(D_n), X)] \sinh \rho d\rho d\theta \\ &= n \cosh d_n \int_{-\pi/n}^{\pi/n} \int_0^r (\cosh d_n \cosh \rho - \cos \theta \sinh d_n \sinh \rho) \sinh \rho d\rho d\theta \\ &= n \cosh^2 d_n \int_{-\pi/n}^{\pi/n} \int_0^r \cosh \rho \sinh \rho d\rho d\theta \end{aligned} \tag{4}$$

$$\begin{aligned}
& -n \cosh d_n \sinh d_n \int_{-\pi/n}^{\pi/n} \int_0^r \cos \theta \sinh^2 \rho d\rho d\theta \\
&= \cosh^2 d_n \pi \sinh^2 r - n \cosh d_n \sinh d_n \cdot 2 \sin \frac{\pi}{n} \int_0^r \frac{\cosh 2\rho - 1}{2} d\rho \\
&= \pi \cosh^2 d_n \sinh^2 r - n \sinh d_n \cosh d_n \sin \frac{\pi}{n} \left(\frac{\sinh 2r}{2} - r \right).
\end{aligned}$$

Division by $\pi \sinh^2 r$ yields

$$1 = \cosh^2 d_n - \frac{n}{\pi} \sin \frac{\pi}{n} \sinh d_n \cosh d_n \frac{\sinh 2r - 2r}{\cosh 2r - 1}$$

or

$$\sinh^2 d_n = \frac{n}{\pi} \sin \frac{\pi}{n} \sinh d_n \cosh d_n \frac{\sinh 2r - 2r}{\cosh 2r - 1}$$

or

$$\tanh d_n = \frac{n}{\pi} \sin \left(\frac{\pi}{n} \right) \frac{\sinh 2r - 2r}{\cosh 2r - 1}.$$

It follows from Eq'n (4) that

$$\text{mass}(D_n) = \frac{\pi \sinh^2 r}{n \cosh d_n}$$

from which is obtained

$$\text{mass}(D_n(r)) = \frac{\pi \sinh^2 r}{n} \sqrt{1 - \left[\frac{n}{\pi} \sin \left(\frac{\pi}{n} \right) \frac{\sinh 2r - 2r}{\cosh 2r - 1} \right]^2}.$$

Q.E.D.

Note that by the proposition above

$$\frac{d_n}{r} = \frac{n}{\pi} \sin \left(\frac{\pi}{n} \right) \left(\frac{2}{3} + O(r^2) \right)$$

in comparison to the Euclidean analog of

$$\frac{2n}{3\pi} \sin \left(\frac{\pi}{n} \right).$$

We turn next to some polygons. In both the statement and the proof below, the index i is computed modulo 3.

Proposition 4.4 *Let $\Delta X_1 X_2 X_3$ be a triangular lamina with uniform density λ and let O be point in its interior. Then*

$$\text{mass}(\Delta X_1 X_2 X_3) = \frac{\lambda}{2} \sum_{i=1}^3 \sinh[(d(O, X_i X_{i+1}))] d(X_i, X_{i+1}).$$

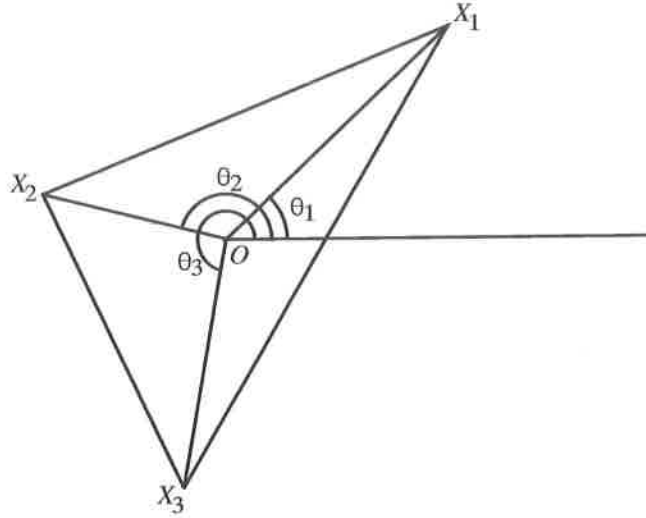

Figure 4:

PROOF: To find the mass of the triangle we may assume that the point O is the origin of a Gaussian parametrization of the hyperbolic plane (Fig. 4). Then

$$\begin{aligned} \text{mass}(\Delta X_1 X_2 X_3) &= \lambda \int \int_{\Delta X_1 X_2 X_3} \cosh \rho dA \\ &= \lambda \sum_{i=1}^3 \int \int_{\Delta O X_i X_{i+1}} \cosh \rho dA. \end{aligned}$$

Let

$$\rho_i = \rho_i(\theta) = \coth^{-1}(C_i \cos(\theta - \alpha_i))$$

be the equation of the geodesic joining X_{i+1} and X_{i+2} . If, for $i = 1, 2, 3$, θ_i is the angle from the horizontal axis to the geodesic $O X_i$ then

$$\begin{aligned} \int \int_{\Delta O X_i X_{i+1}} \cosh \rho dA &= \int_{\theta_i}^{\theta_{i+1}} \int_0^{\rho_{i+2}(\theta)} \cosh \rho \sinh \rho d\rho d\theta \\ &= \frac{1}{2} \int_{\theta_i}^{\theta_{i+1}} \sinh^2 \rho_{i+2} d\theta \\ &= \frac{1}{2} \int_{\theta_i}^{\theta_{i+1}} \sinh^2[(\coth^{-1}(C_{i+2} \cos(\theta - \alpha_{i+2})))]^2 d\theta \\ &= \frac{1}{2} \int_{\theta_i}^{\theta_{i+1}} \frac{d\theta}{C_{i+2}^2 \cos^2(\theta - \alpha_{i+2}) - 1}. \end{aligned}$$

On the other hand, the length of the geodesic segment joining $X_i X_{i+1}$ is

$$\begin{aligned}
d(X_i, X_{i+1}) &= \int_{\theta_i}^{\theta_{i+1}} \sqrt{d\rho_{i+2}^2 + \sinh^2 \rho_{i+2} d\theta^2} \\
&= \int_{\theta_i}^{\theta_{i+1}} \sqrt{\frac{C_{i+2}^2 \sin^2(\theta - \alpha_{i+2})}{(C_{i+2}^2 \cos^2(\theta - \alpha_{i+2}) - 1)^2} + \frac{1}{C_{i+2}^2 \cos^2(\theta - \alpha_{i+2}) - 1}} d\theta \\
&= \sqrt{C_{i+2}^2 - 1} \int_{\theta_i}^{\theta_{i+1}} \frac{d\theta}{C_{i+2}^2 \cos^2(\theta - \alpha_{i+2}) - 1} \\
&= \sqrt{C_{i+2}^2 - 1} \int \int_{\Delta O X_i X_{i+1}} \cosh \rho dA
\end{aligned}$$

Set $d_i = d(O, X_{i+1} X_{i+2})$. Then

$$\sqrt{C_i^2 - 1} = \sqrt{\coth^2 d_i - 1} = \operatorname{csch} d_i$$

Hence,

$$\int \int_{\Delta O X_i X_{i+1}} \cosh \rho dA = \frac{\sinh d_{i+2}}{2} d(X_i, X_{i+1})$$

and the proposition now follows immediately. Q.E.D.

Note that the formula of the proposition above has a Euclidean analog, namely,

$$\operatorname{mass}(\Delta X_1 X_2 X_3) = \frac{\lambda}{2} \sum_{i=1}^3 d(O, X_i X_{i+1}) d(X_i, X_{i+1}).$$

where O is any point in the interior of the triangle and d denotes Euclidean distance.

The same technique can also be used to prove another formula whose Euclidean analog is also well known.

Proposition 4.5 *The mass of the regular n -gon of in-radius r and uniform density 1 is half the product of its perimeter with $\sinh r$.*

PROOF: Once again we work in the Gauss model of the hyperbolic plane. Set $C = \coth r$ and let a be the hyperbolic length of one of the polygon's sides (see Fig. 5). Then one side of the polygon is parametrized as

$$\rho = \coth^{-1}(C \cos \theta), \quad -\pi/n \leq \theta \leq \pi/n.$$

It follows from the symmetry of the polygon that its mass equals

$$2n \int_0^{\pi/n} \int_0^{\coth^{-1}(C \cos \theta)} \cosh \rho \sinh \rho d\rho d\theta$$

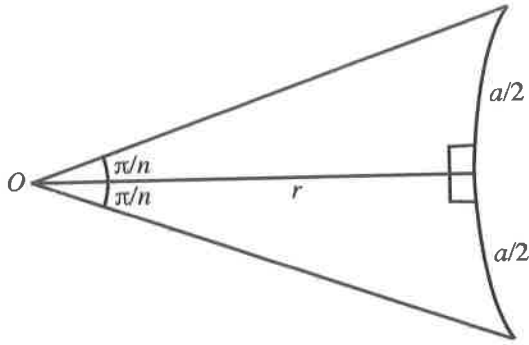

Figure 5:

$$\begin{aligned}
 &= n \int_0^{\pi/n} [\sinh(\coth^{-1}(C \cos \theta))]^2 d\theta \\
 &= n \int_0^{\pi/n} \left[\frac{\sqrt{\frac{C \cos \theta + 1}{C \cos \theta - 1}} - \sqrt{\frac{C \cos \theta - 1}{C \cos \theta + 1}}}{2} \right]^2 d\theta \\
 &= n \int_0^{\pi/n} \frac{d\theta}{C^2 \cos^2 \theta - 1} = \frac{n}{\sqrt{C^2 - 1}} \tanh^{-1} \left[\frac{\tan(\pi/n)}{\sqrt{C^2 - 1}} \right] \\
 &= n \sinh r \tanh^{-1} [\tan(\pi/n) \sinh r] \\
 &= n \sinh r \tanh^{-1} \left[\tanh \left(\frac{a}{2} \right) \right] = \frac{na \sinh r}{2}.
 \end{aligned}$$

Q.E.D.

The area of the above regular polygon is well known to be

$$(n - 2)\pi - 2n\beta,$$

where β is the angle at its vertices. Thus the mass of the uniform regular polygon is also "better behaved" than its area.

Next, the mass of the uniform triangle is expressed in terms of its sides, thus obtaining an analog of Heron's formula for the area of a Euclidean triangle.

Lemma 4.6 *Let ABC be a hyperbolic triangle whose medians AP , BQ , CR intersect at O . Then*

$$\frac{\sinh AO}{\sinh OP} = \frac{\sinh BO}{\sinh OQ} = \frac{\sinh CO}{\sinh OR} = \delta$$

where

$$\delta^2 = 3 + 2 \cosh a + 2 \cosh b + 2 \cosh c$$

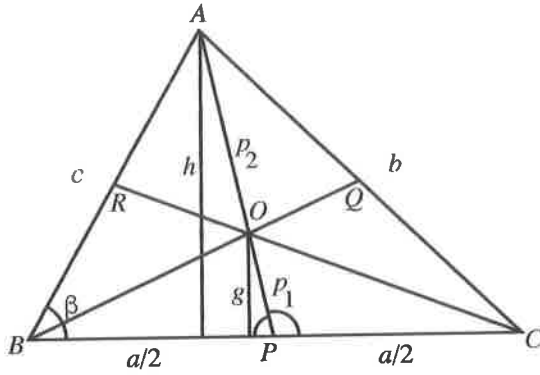

Figure 6:

PROOF: Let $p = d(A, P)$, $p_1 = d(O, P)$ (Fig. 6). By the Hyperbolic Law of Cosines,

$$\cos \angle APB = \frac{\cosh p \cosh a/2 - \cosh b}{\sinh p \sinh a/2}$$

and

$$\cos \angle APC = \frac{\cosh p \cosh a/2 - \cosh c}{\sinh p \sinh a/2}.$$

From the addition of these formulas we obtain

$$2 \cosh p \cosh a/2 = \cosh b + \cosh c.$$

An application of the unsigned Theorem of Menelaus to $\triangle ACR$ and transversal BOQ yields

$$\frac{\sinh b/2}{\sinh b/2} \frac{\sinh a}{\sinh a/2} \frac{\sinh p_1}{\sinh p_2} = 1$$

from which it follows that

$$\frac{\sinh p_2}{\sinh p_1} = \frac{\sinh a}{\sinh a/2} = 2 \cosh a/2.$$

Hence,

$$2 \cosh a/2 = \frac{\sinh(p - p_1)}{\sinh p_1} = \sinh p \coth p_1 - \cosh p$$

and

$$\coth p_1 = \frac{\cosh p + 2 \cosh a/2}{\sinh p}$$

$$\frac{1}{\sinh^2 p_1} = \left(\frac{\cosh p + 2 \cosh a/2}{\sinh p} \right)^2 - 1$$

Therefore

$$\frac{\sinh^2 p}{\sinh^2 p_1} = (\cosh p + 2 \cosh a/2)^2 - \sinh^2 p$$

$$\begin{aligned}
&= 1 + 4 \cosh p \cosh a/2 + 4 \cosh^2 a/2 \\
&= 1 + 2 \cosh b + 2 \cosh c + 4 \frac{\cosh a + 1}{2} \\
&= 3 + 2 \cosh a + 2 \cosh b + 2 \cosh c.
\end{aligned}$$

Q.E.D.

Theorem 4.7 *Let the homogeneous hyperbolic ΔABC have constant density λ and set*

$$\Delta = \sqrt{1 - \cosh^2 a - \cosh^2 b - \cosh^2 c + 2 \cosh a \cosh b \cosh c.}$$

and

$$\delta = \sqrt{3 + 2 \cosh a + 2 \cosh b + 2 \cosh c.}$$

Then

$$\text{mass}(\Delta ABC) = \frac{\lambda \Delta}{2\delta} \left(\frac{a}{\sinh a} + \frac{b}{\sinh b} + \frac{c}{\sinh c} \right)$$

PROOF: Let h and g be the hyperbolic distances from A and O to BC (see Fig. 6). By the hyperbolic trigonometry of the right triangle

$$\frac{\sinh h}{\sinh p} = \sin \angle APB = \frac{\sinh g}{\sinh p_1}$$

so that

$$\sinh g = \frac{\sinh h}{\delta} = \frac{\sin \beta \sinh c}{\delta}$$

It now follows from Proposition 4.6 that

$$\text{mass}(\Delta ABC) = \frac{\lambda}{2\delta} (a \sin \beta \sinh c + b \sin \gamma \sinh a + c \sin \alpha \sinh b)$$

and so, by the hyperbolic Law of Sines

$$\text{mass}(\Delta ABC) = \frac{\lambda}{2\delta} \left(\frac{a}{\sinh a} + \frac{b}{\sinh b} + \frac{c}{\sinh c} \right) \Delta.$$

Q.E.D.

Perron proved that the triangle of Theorem 4.7 has mass

$$\frac{\lambda}{2} \sqrt{2bc \cos \alpha + 2ca \cos \beta + 2ab \cos \gamma - a^2 - b^2 - c^2}$$

but suggested that it would be of interest to obtain a formula with a radicand that is clearly positive. Since the quantity Δ^2 is well known to be positive [Stahl2, p. 106], Theorem 4.7 does indeed fulfill Perron's suggestion. We also note in passing that, as was known to Perron, it follows from the second equation of Theorem 3.1 that the quantity δ of Theorem 4.7 is the total mass of the discrete system obtained by placing unit masses at the vertices of ΔABC .

It is well known that the hyperbolic areas of triangles are bounded above by π . Such is not the case for the hyperbolic mass.

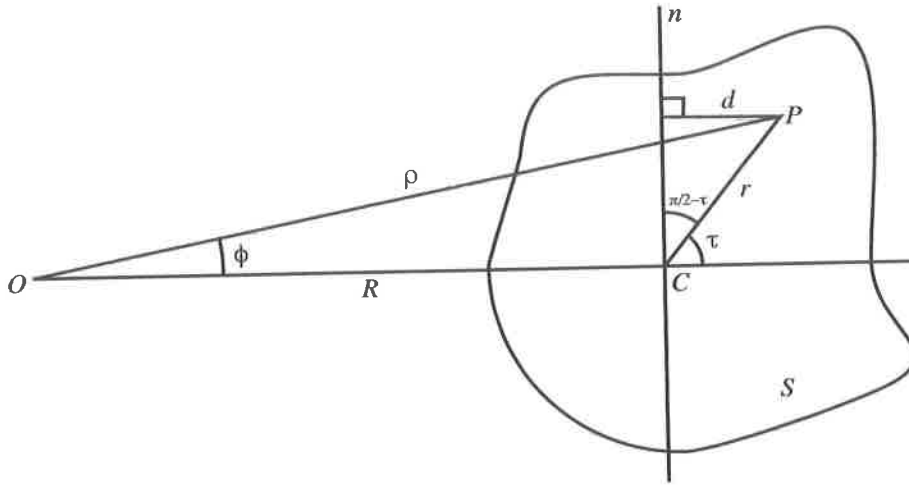

Figure 7:

Corollary 4.8 *There exist hyperbolic triangles of arbitrarily large mass.*

PROOF: Let $a = b = c$ go to infinity in the expression derived in Theorem 4.7. Q.E.D.

5 HIGHER DIMENSIONS

The following is the hyperbolic analog of a Theorem of Pappus. It has been generalized by Robert Foote [Foote 2] in the manner of [Foote 1]. Note that the Gaussian metric on H^3 is [Ratcliffe, p. 77]

$$ds^2 = d\rho^2 + \sinh^2 \rho \sin^2 \phi d\theta^2 + \sinh^2 \phi d\phi^2$$

with volume element

$$dV = \sinh^2 \rho \sin \phi d\rho d\theta d\phi$$

Theorem 5.1 *In hyperbolic space, let D be the solid formed by rotating a planar region S about an axis m that does not intersect S , and let R denote the distance from the center of mass of S to m . Then the volume of D equals the product of the 2-dimensional mass of S by the distance traveled by S 's center of mass.*

PROOF: Let O be the foot of the perpendicular from S 's centroid C to the axis m . If P is an arbitrary point of S , let its polar coordinates be (ρ, ϕ) and (r, τ) as indicated in Figure 7. Finally, let n be a straight line perpendicular to OC at C .

By the Law of Sines

$$\sinh \rho \sin \phi = \sinh r \sin \tau$$

and hence

$$\cosh \rho \sin \phi d\rho + \sinh \rho \cos \phi d\phi = \cosh r \sin \tau dr + \sinh r \cos \tau d\tau. \quad (5)$$

By the Law of Cosines

$$\cosh \rho = \cosh R \cosh r + \cos \tau \sinh R \sinh r$$

and hence

$$\sinh \rho d\rho = (\cosh R \sinh r + \cos \tau \sinh R \cosh r) dr - \sin \tau \sinh R \sinh r d\tau. \quad (6)$$

When the wedge product of Eq'ns 5 and 6 is taken, we obtain

$$\begin{aligned} & \sinh^2 \rho \cos \phi d\phi \wedge d\rho \\ &= (\cosh R \sinh^2 r \cos \tau + \cos^2 \tau \sinh r \cosh r \sinh R) d\tau \wedge dr \\ & \quad - \sin^2 \tau \sinh R \sinh r \cosh r) dr \wedge d\tau \\ &= (\cosh R \sinh^2 r \cos \tau + \sinh r \cosh r \sinh R) d\tau \wedge dr. \end{aligned}$$

Consequently

$$\begin{aligned} \text{vol}(D) &= \int \int \int_D \sinh^2 \rho \cos \phi d\phi \wedge d\rho \wedge d\theta \\ &= 2\pi \int \int_S \sinh^2 \rho \cos \phi d\phi \wedge d\rho \\ &= 2\pi \cosh R \int \int_S \sinh^2 r \cos \tau d\tau \wedge dr \\ & \quad + 2\pi \sinh R \int \int_S \sinh r \cosh r d\tau \wedge dr \\ &= 2\pi \cosh R \int \int_S \sinh^2 r \sin(\pi/2 - \tau) d\tau \wedge dr + 2\pi \sinh R \cdot \text{mass}(S) \\ &= 2\pi \cosh R \int \int_S \sinh d \sinh r d\tau \wedge dr + 2\pi \sinh R \cdot \text{mass}(S) \\ &= 2\pi \cosh R \cdot M_n(S) + 2\pi \sinh R \cdot \text{mass}(S) \\ &= 2\pi \cosh R \cdot 0 + 2\pi \sinh R \cdot \text{mass}(S) \end{aligned}$$

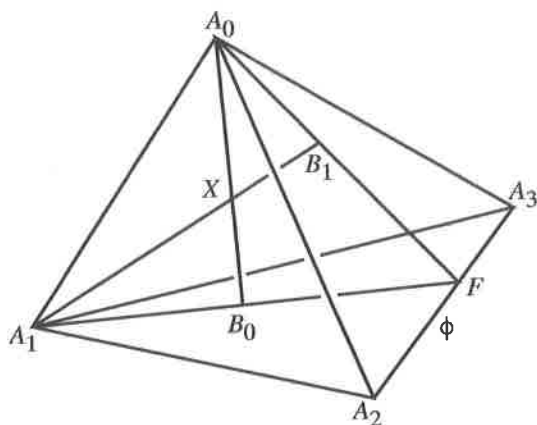

Figure 8:

It follows that

$$\text{vol}(D) = 2\pi \sinh R \cdot \text{mass}(S).$$

Q.E.D.

An n -simplex of H^n is a set of $n+1$ points (vertices) $\sigma = \{A_0, A_1, \dots, A_n\}$ that are not contained in any $n-1$ dimensional hyperplane. The convex hull of σ is the *solid simplex* denoted by $|\sigma|$. A *facet* σ^i of σ is the $(n-1)$ -simplex obtained by deleting A_i from σ . A *cevian* of a simplex is a line segment that joins a vertex to some point in its opposite facet. The Euclidean version of the following theorem was proved in [Landy].

Theorem 5.2 A set $\{A_0B_0, A_1B_1, \dots, A_nB_n\}$ of cevians of the simplex $\sigma = \{A_0, A_1, \dots, A_n\}$ in H^n is concurrent if and only for each $k = 0, 1, \dots, n$ the vertex A_k can be assigned a weight so that the centroid of each weighted facet is located at B_k .

PROOF: Suppose first that for each $k = 0, 1, \dots, n$, the vertex A_k has been assigned a weight a_k so that the centroid of the opposite facet is (B_k, b_k) . Then the centroid of the weighted σ lies on each line segment A_kB_k and so the cevians in question are concurrent.

The converse is proved by induction on n . The cases $n = 1, 2$ are immediate. The case $n = 2$ follows easily from the Theorem of Ceva. Assume the theorem holds for all simplices of dimension $n-2$, where $n \geq 3$. Suppose the cevians $A_iB_i, i = 0, 1, 2, \dots, n$, are concurrent at X . Since the straight lines A_0B_0 and A_1B_1 intersect at X they span a plane, say α . Let σ be the simplex $\{A_2, A_3, \dots, A_n\}$. We now show that both A_0B_1 and A_1B_0 intersect $|\sigma|$ in the same point.

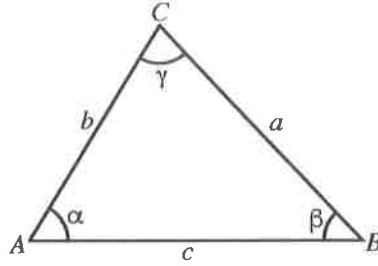

Figure 9:

Note that both straight lines contain points not in the subspace spanned by σ and hence, by Pasch's postulate, each intersects $|\sigma|$ in exactly one point, which points are necessarily in $\alpha \cap |\sigma|$ (See Fig. 8). If the two intersection points were distinct, then $\alpha \cap |\sigma|$, being convex, would be a line segment, thus implying that α and $|\sigma|$ would span an $(n-1)$ -dimensional subspace of H^n and contradicting the fact that $\{A_0, A_1, \dots, A_n\}$ is a simplex. Hence we conclude that there is a point F such that

$$A_0B_1 \cap A_1B_0 \cap |\sigma| = \{F\}.$$

Let the vertices A_2, A_3, \dots, A_n of σ be assigned the respective weights $\lambda_2, \lambda_3, \dots, \lambda_n$ so that their centroid is (F, λ_{01}) , for some real number λ_{01} . Let λ_0, λ_1 be weights such that

$$\begin{aligned} & \mathcal{C}(\{(A_0, \lambda_0), (A_2, \lambda_2), \dots, (A_n, \lambda_n)\}) \\ &= \mathcal{C}(\{(A_0, \lambda_0), (F, \lambda_{01})\}) = (B_1, \cdot) \end{aligned}$$

and

$$\begin{aligned} & \mathcal{C}(\{(A_1, \lambda_1), (A_2, \lambda_2), \dots, (A_n, \lambda_n)\}) \\ &= \mathcal{C}(\{(A_1, \lambda_1), (F, \lambda_{01})\}) = (B_0, \cdot) \end{aligned}$$

Then, by Prop'n 3.3,

$$\begin{aligned} & \mathcal{C}(\{(A_0, \lambda_0), (A_1, \lambda_1), \dots, (A_n, \lambda_n)\}) \\ &= \mathcal{C}(\{(A_0, \lambda_0), (A_1, \lambda_1), (F, \lambda_{01})\}) = (X, \cdot) \end{aligned}$$

Q.E.D.

6 FORMULAS OF THE HYPERBOLIC TRIANGLE

Theorem 6.1 *Let $\triangle ABC$ be the hyperbolic triangle of Figure 9 and set*

$$\Delta = \sqrt{1 - \cosh^2 a - \cosh^2 b - \cosh^2 c + 2 \cosh a \cosh b \cosh c}$$

Then

$$\frac{\sinh a}{\sin \alpha} = \frac{\sinh b}{\sin \beta} = \frac{\sinh c}{\sin \gamma} = \frac{\Delta}{\sinh a \sinh b \sinh c} \quad (\text{Law of Sines})$$

$$\cosh a = \cosh b \cosh c - \cos \alpha \sinh b \sinh c \quad (\text{Law of Cosines})$$

Theorem 6.2 Let P, Q, R , be points on the respective extended sides AB, BC, AC of the hyperbolic $\triangle ABC$. Then

Theorem of Ceva:

AP, BQ, CR are concurrent

if and only if

$$\frac{\sinh AR}{\sinh RB} \frac{\sinh BP}{\sinh PC} \frac{\sinh CQ}{\sinh QA} = 1;$$

Theorem of Menelaus:

P, Q, R are collinear

if and only if

$$\frac{\sinh AR}{\sinh RB} \frac{\sinh BP}{\sinh PC} \frac{\sinh CQ}{\sinh QA} = -1.$$

7 Acknowledgements

The author is indebted to his colleague David Lerner for his help and patience. He is also indebted to Alexey V. Shchepetilov for corrections as well as information regarding the kinetically defined center of mass [Shchepetilov].

References

- [1] Jules F. C. Andrade, *Leçons de Mécanique Physique*, Société d'Éditions Scientifiques, 1898, pp. 370 - 389.
- [2] Roberto Bonola, *Non-Euclidean Geometry*, Dover Publications, New York, 1955.
- [3] G. D. Chakerian, M. S. Klamkin, The k -centroid of an n -simplex, preprint, 2003.
- [4] E. J. Dijksterhuis, *Archimedes*, (C. Dikshoorn, translator), Princeton University Press, Princeton, 1987.
- [5] Fr. Fabricius-Bjerre, Centroids and medians in spherical space I, *Mat. Tidsskr. B.* 1947, 48-52.

- [6] David Fog, Centroids and medians in spherical space I, *Mat. Tidsskr. B.* 1947, 41-47.
- [7] Robert Foote, The Volume Swept out by a Moving Planar Region, *Mathematics Magazine*, **79** (2006), No. 4, 289 - 297.
- [8] Robert Foote, private communication.
- [9] G. A. Gal'perin, On the Concept of the Center of Mass of a System of Point-Masses In Spaces of Constant Curvature, *Soviet Math. Dokl.* **38** (1989), No. 2, 367 - 371.
- [10] ———, A concept of the mass center of a system of material points in the constant curvature spaces. *Comm. Math. Phys.* **54** (1993), No. 1, 63-84.
- [11] C. F. Gauss, *General Investigations of Curved Surfaces*, Raven Press, Hewlett New York, 1975.
- [12] Marvin J. Greenberg, *Euclidean and non-Euclidean Geometries: Development and History*, W. H. Freeman, 3rd edition, 1995.
- [13] Steven G. Krantz, John E. McCarthy, Harlod R. Parks, Geometric characterizations of centroids of simplices, *J. Math. Anal. Appl.*, **316**(2006), 87 - 109.
- [14] Steven Landy, A Generalization of Ceva's Theorem to Higher Dimensions, *Amer. Math. Monthly* **95**(1988), 936 - 938.
- [15] Oskar Perron, Über Massenmittelpunkt und Schwerpunkt im hyperbolischen Raum, *Mathematikunterricht*, **15**(1969), No. 2, 61-78.
- [16] John G. Ratcliffe, *Foundations of Hyperbolic Geometry*, 2nd edition, Springer New York, 2006.
- [17] Alexey V. Shchepetilov, Two-body problem on two-point homogeneous spaces, invariant differential operators and the mass center concept. *J. Geom. Phys.* **48** (2003), no. 2-3, 245-274.
- [18] Saul Stahl, *Introduction to Topology and Geometry*, John Wiley and Sons, Hoboken New jersey, 2005.
- [19] ———*A Gateway to Modern Geometry: The Poincaré Half-plane*, 2nd edition, Jones and Bartlett, Boston, 2008.
- [20] ———*Mass in the Hyperbolic Plane* arXiv:0705.3448.
- [21] Abraham D. Ungar, The Hyperbolic Triangle Centroid, *Comment. Math. Univ. Carolinae*, **45**(2004), No. 2, 355-369.